



MMB Networks[™]

Layout Guidelines for CSB04PA1x Modules
Revision 0.1

Preliminary Information

Table of Contents

Table of Contents	2
1 Module Placement and PCB Layout Guidelines.....	3
1.1 Module and Footprint Dimensions	3
1.2 PCB Footprint: Metal	4
1.3 PCB Footprint: Soldermask	6
1.4 Layout Guidelines	7
2 Enclosure	9
3 Debugging.....	9
4 Sample Application Circuit	10
5 Revision History	11

Preliminary Information

1 Module Placement and PCB Layout Guidelines

1.1 Module and Footprint Dimensions

The CSB04PA1x-CHP and CSB04PA1x-RFC have identical external dimensions and PCB footprint.

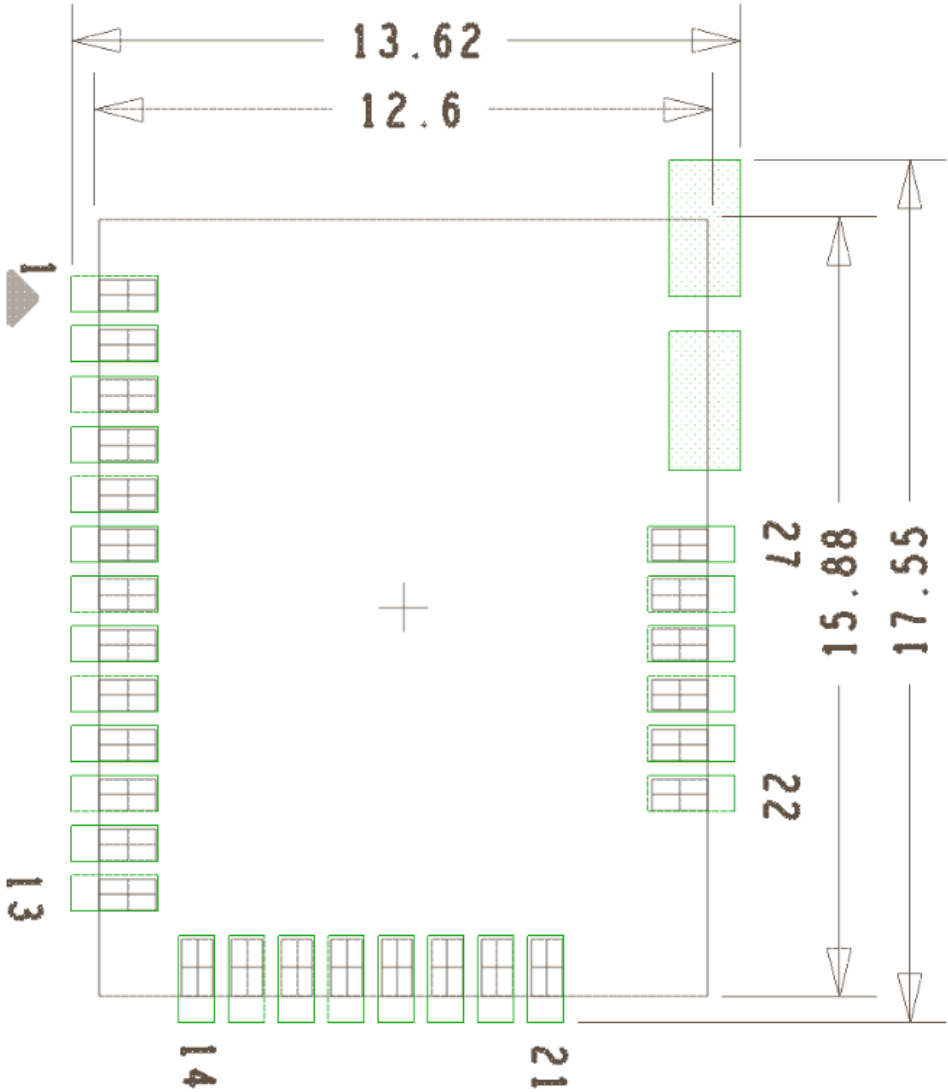

Figure 1: Module and footprint outlines. Dimensions in mm.

Description	Distance
Length of module	15.88 mm
Width of module	12.60 mm
Height of the module	2.88 mm
Total length of footprint	17.55 mm
Total width of footprint	13.62 mm

1.2 PCB Footprint: Metal

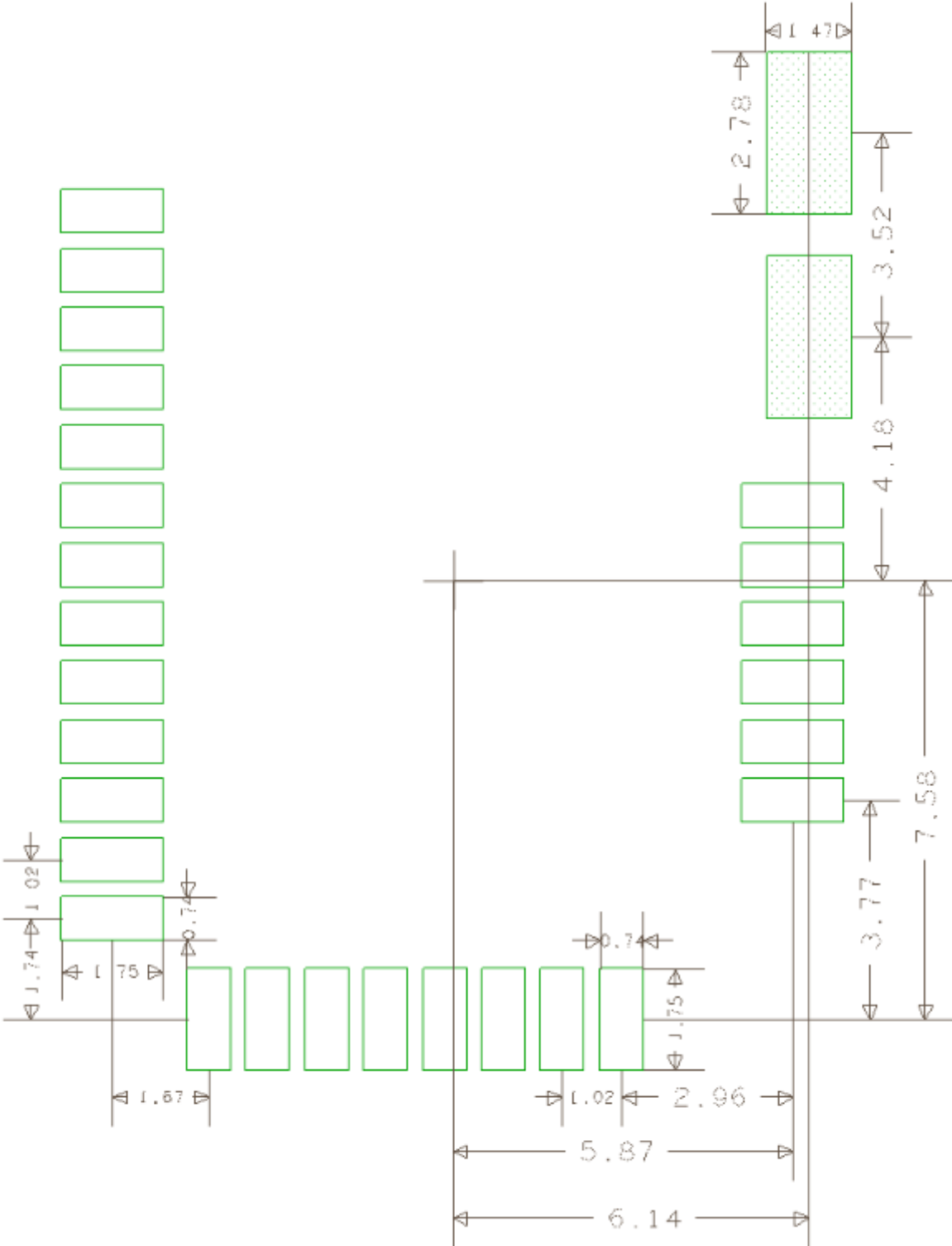

Figure 2: Metal pad size and position. Dimensions in mm

Description	Distance
X distance centre-to-centre, Pad 13 to Pad 14	1.67 mm
Y distance centre-to-centre, Pad 13 to Pad 14	1.74 mm
X distance centre-to-centre, Pad 21 to Pad 22	2.96 mm
Y distance centre-to-centre, Pad 21 to Pad 22	3.77 mm
X distance, module centre to side pad centre	5.87 mm
X distance, module centre to RFGND pad centre	6.14 mm
Y distance, module centre to bottom pad centre	7.58 mm
Y distance, module centre to 1 st RFGND pad centre	4.18 mm
Standard pad pitch	1.02 mm
Standard pad metal width	0.74 mm
Standard pad metal length	1.75mm
RFGND pad pitch	3.52 mm
RFGND pad metal width	1.47 mm
RFGND pad metal length	2.78 mm

Preliminary Information

1.3 PCB Footprint: Soldermask

It is recommended that soldermask-defined (SMD) pads be used for the CSB04PA1x modules. All soldermask openings are centered at the same points as the corresponding pads.

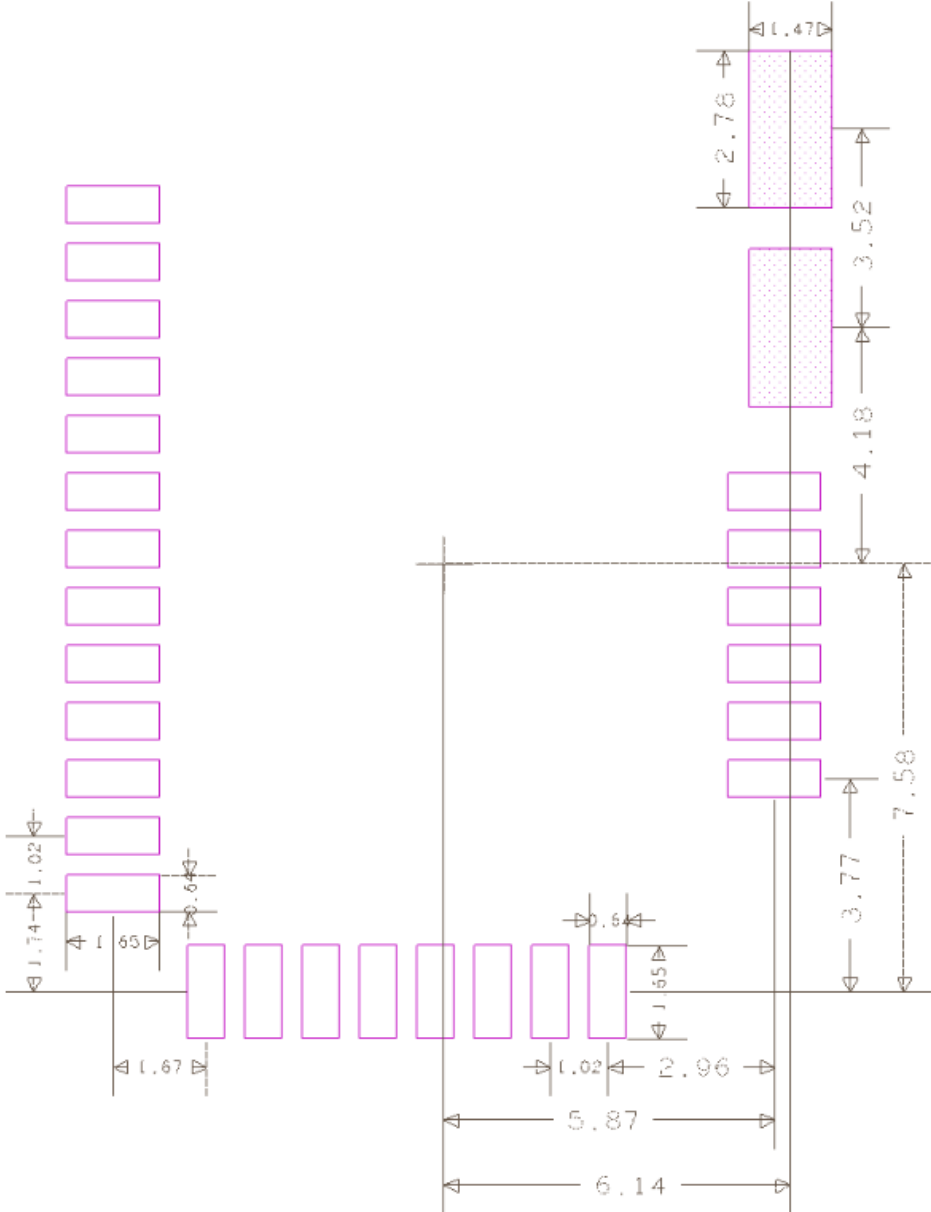

Figure 3: Soldermask opening size and position. Dimensions in mm.

Description	Distance
Standard pad soldermask opening width	0.64 mm
Standard pad soldermask opening length	1.65 mm
RFGND pad soldermask opening width	1.47 mm
RFGND pad soldermask opening length	2.78 mm

1.4 Layout Guidelines

For optimal performance of the CSB04PA1x-CHP (with onboard chip antenna), please follow the PCB layout guidelines and ground plane recommendations in this document.

- Place the module at the edge of the PCB with the recommended RF ground and keepout areas as shown in Figure 4. The keepout area is necessary for optimal performance of the antenna and metallization should be removed from this area on all layers of the PCB.
- Connect all ground pads to a solid ground plane.
- Place the ground vias as close to the ground pads as possible. The RFGND pads should each contain at least 3 vias.
- Do not place plastic or any other dielectric material in direct contact with the antenna.

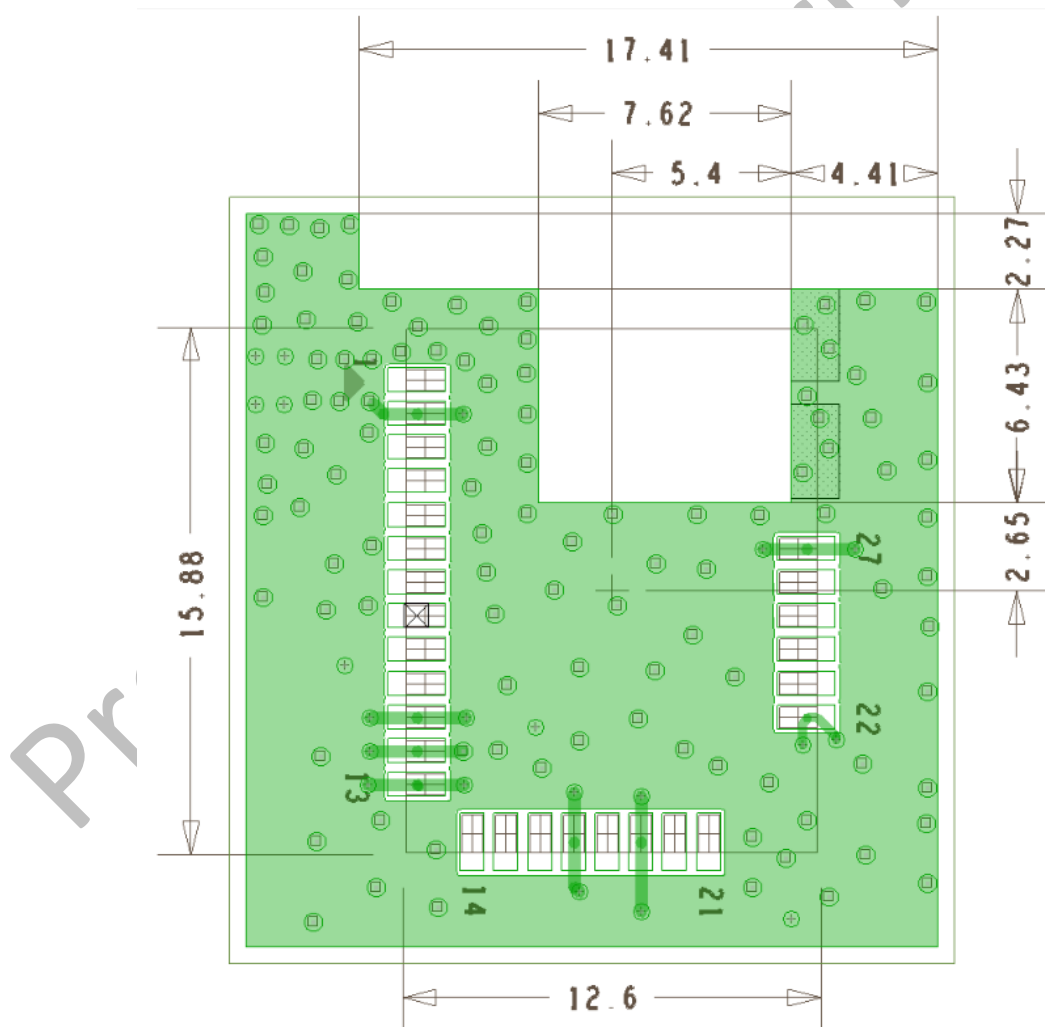

Figure 4: RF ground and antenna keepout for CSB04PA1x-CHP. Dimensions in mm.

Description	Distance
Length (Y-dimension) of module	15.88 mm
Width (X-dimension) of module	12.60 mm
Y distance, module center to edge of 1 st keepout	2.65 mm
Length (Y-dimension) of 1 st keepout	6.43 mm
Length (Y-dimension) of 2 nd keepout	2.27 mm
X distance, module center to edge of 1 st keepout	5.4 mm
Width (X-dimension) of 1 st keepout	7.62 mm
Width (X-dimension) of 2 nd keepout	17.41 mm
Minimum width (X-dimension) of RFGND strip	4.41 mm

If the design is unable to meet the layout guidelines for the CSB04PA1x-CHP, then it is recommended that the CSB04PA1x-RFC or CSB04PA1x-PIN be used instead. These modules provide a connection to an external antenna, which can be mounted to the enclosure. See the CSB04PA1x datasheet for a list of pre-certified antenna part numbers. If you would like to use a different antenna, please contact your MMB Networks Account Manager for more information on the certification process.

2 Enclosure

Please select materials suitable for 2.4GHz RF for an enclosure if applicable. Avoid using any metal or metal coatings on the enclosure as metals can have a significant impact on the radiation pattern of the antenna.

3 Debugging

In order to use an external debugger with the CSB04PA1x module it is recommended to add the mini simplicity connector to the design. Figure 2 below shows the pin out for the Mini Simplicity connector.

VAEM	1	2	GND
RST	3	4	VCOM_RX
VCOM_TX	5	6	SWO
SWDIO	7	8	SWCLK
PTI_FRAME	9	10	PTI_DATA

Pin #	Pin Name	Description
1	VAEM	Target voltage on the debugged application. Supplied and monitored by the AEM when power selection switch is in the AEM position
2	GND	Ground
3	RST	Reset
4	VCOM_RX	Virtual COM Rx
5	VCOM_TX	Virtual COM Tx
6	SWO	Serial Wire Output
7	SWDIO	Serial Wire Data
8	SWCLK	Serial Wire Clock
9	PTI_FRAME	Packet Trace Frame Signal
10	PTI_DATA	Packet Trace Data Signal

Figure 5: Mini simplicity debug connector

For more information on debugging, refer to the application titled '*AN958: Debugging and Programming Interfaces for Custom Designs*' by Silicon Labs.

4 Sample Application Circuit

A sample application circuit for the CSB04PA1x module is provided below.

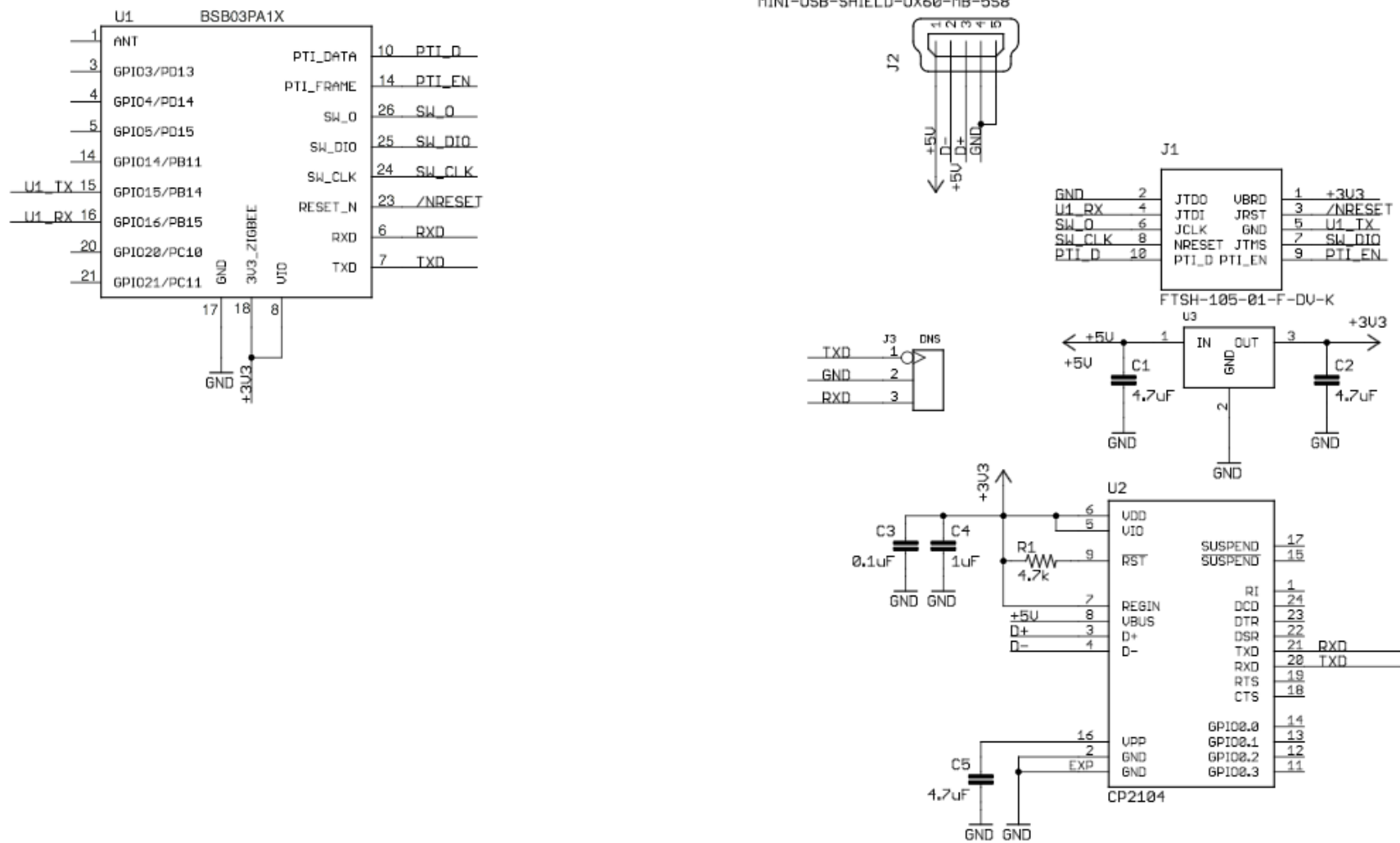

Figure 6: Sample Application Circuit for a CSB04PA10X Module

5 Revision History

Revision	Date	Comments
0.1	19 Mar 2019	Initial draft

Preliminary Information